

圓形斜度鎖 Round Taper Lock (公制)

材質 Material: SUJ2

硬度 Hardness: 58HRC ± 2

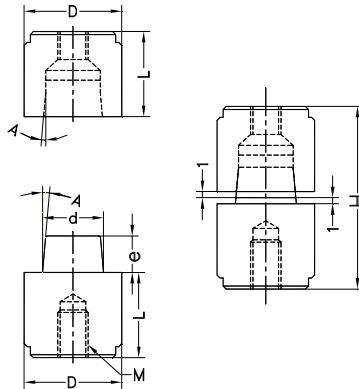

單位Unit:MM

型號 Nom. Size	D		L ^{+0.2} / _{+0.1}	H ^{+0.4} / _{+0.2}	d	e	M	A
	Size	Tol.						
ML-TP016	16	+0.012 +0.001	14	30	10	6	M5	5°
ML-TP020	20	+0.015 +0.002	19	40	13	9	M6	
ML-TP025	25		24	50	16	12	M8	
ML-TP030	30		29	60	20	15	M10	
ML-TP035	35	+0.018 +0.002	34	70	24	18	M12	

頂鎖 Top Lock(公制)

材質 Material: YK30

硬度 Hardness: 58HRC ± 2

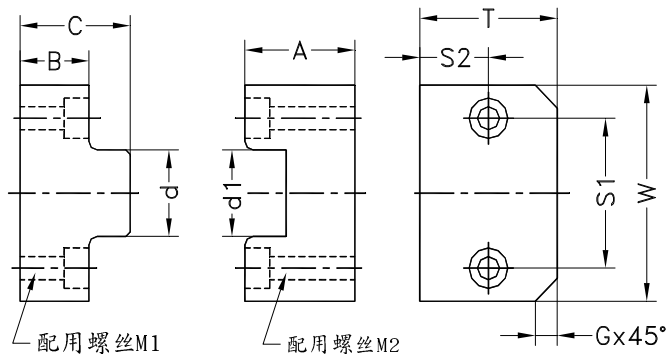
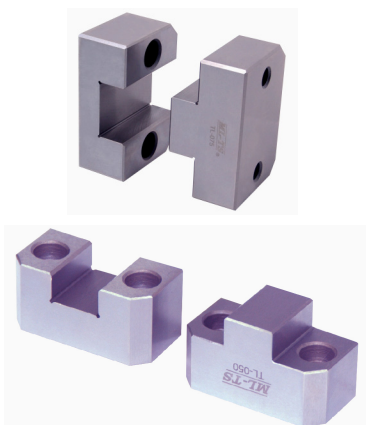

單位Unit:MM

型號 Nom. Size	W ⁰ / _{-0.01}	T	A	B	C	d1 ^{+0.005} / ₀	d ⁰ / _{-0.005}	G	M1	M2	S1	S2
ML-TL050	50	25	25	20	30	17	17	5	M6x20	M6x25	34	12.5
ML-TL075	75	50	30	25	40	30	30	8	M8x25	M8x30	52	25